

Pressure Reducing Valve

ESG[®]

700 SERIES

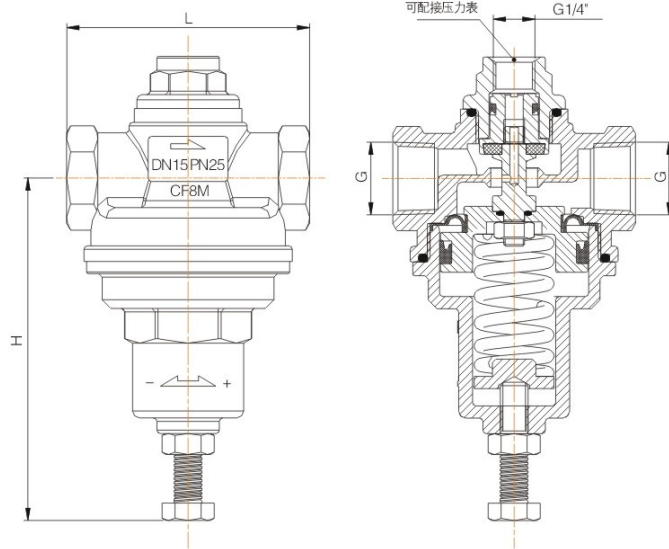

Advantages

1. Valve body is made by Stainless Steel CF8M, suitable for fluid, air.
2. Design of piston and diaphragm improves the inability of sustaining pressure and leakage.
3. When the outlet pressure responds directly to the pressure control chamber and adjusts the setting pressure, it responds quickly and adjusts the pressure accurately.

Technical Data

Nominal Pressure: PN25
 Pressure Adjusting Range : 1-6bar、4-10bar、8-13bar
 Fluid Temperature: -15-+100°C
 Seals Material: FPM
 Normally Open
 Connection: Thread(BSP,BSPT,NPT)
 Valve Body Testing 35kgf/Cm2

Main Dimension

Size	G	H	L	Kv(m ³ /h)
DN15	1/2"	100	70	2.1
DN20	3/4"	100	85	7.7
DN25	1"	105	92	9.4