

2-JAW PARALLEL GRIPPERS

SERIES GP

▶ PRODUCT ADVANTAGES

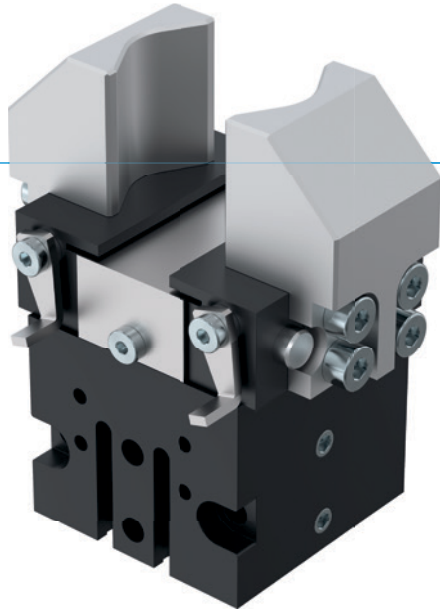

“The enduring”

▶ Proven technology

We have more than 20 years of proven reliability, which ensures uninterrupted production for you





▶ Very short cycle times

Low-friction circular guides enable very short cycle times and, therefore, high component output for your machine

▶ Failure-free continuous operation

Our uncompromising “Made in Germany” quality guarantees up to 10 million maintenance-free cycles

▶ SERIES CHARACTERISTICS

Installation size	Version	
GPXXX	-C/D	S-C/D
 Spring closing C		•
 High-strength S		•
 10 million maintenance-free cycles (max.)	•	•
 Inductive sensor	•	•
 Magnetic field sensor	•	•
 IP30	•	•



► BENEFITS IN DETAIL

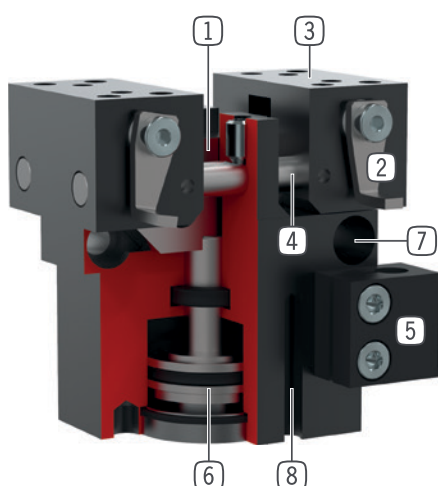

- ① **Wedge hook mechanism**
 - synchronized the movement of the gripper jaws
 - high force transfer
- ② **Adjustable switch cam**
 - for position sensing
- ③ **Gripper jaw**
 - individual gripper finger mounting
- ④ **Roller slide**
 - for low wear movement sequence
- ⑤ **Mounting block**
 - mounting for inductive proximity switch
- ⑥ **Drive**
 - double-acting pneumatic cylinder
- ⑦ **Mounting and positioning**
 - mounting possible from several sides for versatile positioning
- ⑧ **Sensing slot**
 - mounting and positioning of magnetic field sensors

► TECHNICAL DATA

Installation size	Stroke per jaw [mm]	Gripping force [N]	Weight [kg]	IP class
GP12	3	8,4	0.033	IP30
GP19	4	36	0.081	IP30
GP30	5	94	0.15	IP30
GP45	5	118 - 190	0.255 - 0.3	IP30
GP75	10	220 - 275	0.45 - 0.5	IP30
GP100	8 - 13	450 - 5250	1.3	IP30

► FURTHER INFORMATION IS AVAILABLE ONLINE



All information just a click away at: www.zimmer-group.com. Find data, illustrations, 3D models and operating instructions for your installation size using the order number for your desired product. Quick, clear and always up-to-date.

2-JAW PARALLEL GRIPPERS

INSTALLATION SIZE GP12

▶ PRODUCT SPECIFICATIONS



▶ Gripping force diagram

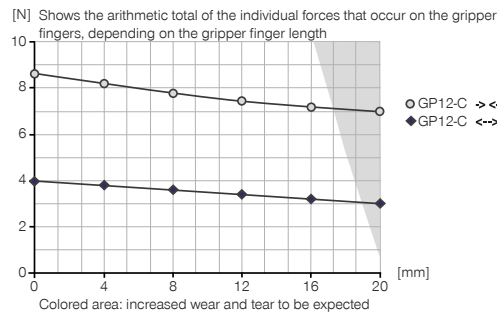

▶ Forces and moments

Displays static forces and moments that can also have an effect, besides the gripping force.

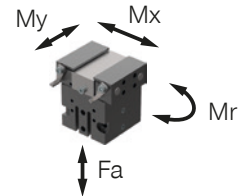

Mr [Nm]	0.15
Mx [Nm]	0.15
My [Nm]	0.15
Fa [N]	15

▶ RECOMMENDED ACCESSORIES



GRIPPING COMPONENTS



UB12
Universal jaw set aluminium



SENSORS



NJ3-E2
Inductive proximity switch - Cable 5 m



ENERGY SUPPLY



GVM3
Straight Fittings - Barb Style Connection



NJ3-E2SK
Inductive Proximity Switch Cable 0,3 m - Connector M8



WVM3
Angled Fittings - Barb Style Connection



MFS01-S-KHC-P1-PNP
Magnetic field sensor angled, cable 0.3 m - M8 connector



DEV04
Quick Exhaust Valve



MFS02-S-KHC-P1-PNP
Magnetic field sensor straight, cable 0.3 m - M8 connector



DSV1-8
Pressure safety valve



MFS01-S-KHC-P2-PNP
2-point sensor angled, cable 0.3 m - M8 connector



DSV1-8E
Pressure safety valve with quick exhaust



MFS02-S-KHC-P2-PNP
2-point sensor straight, cable 0.3 m - M8 connector



CONNECTIONS / OTHER



SENSORS



KB3M
Mounting block



KAG500
Plug-in connector Straight Cable 5m - Socket M8 (female)



ZE10H7X6
Centering Disc

Order no.	GP12-C
Stroke per jaw [mm]	3
Gripping force in closing [N]	8.4
Gripping force in opening [N]	4
Gripping force secured by spring min. [N]	
Closing time [s]	0.02
Opening time [s]	0.02
Repetition accuracy +/- [mm]	0.05
Operating pressure min. [bar]	3
Operating pressure max. [bar]	8
Nominal operating pressure [bar]	6
Operating temperature min. [°C]	+5
Operating temperature max. [°C]	+80
Air volume per cycle [cm ³]	0.4
Protection to IEC 60529	IP30
Weight [kg]	0.033

