

Float & Board Tank Gauge - FBG

An economical, easy to install gauge for level indication of liquids in bulk storage tanks under atmospheric condition.

Salient Features

- Durable aluminum powder coated gauge board
- Gauge board markings visible from distance

Options

- SS304, SS316, PP or ECTFE coated SS to suit various liquids
- Half travel gauge board for underground tanks
- Seal pot for fuming liquids
- Adjustable alarm switches (max 4)
- Volumetric calibration in Litres or KL or BBL

Construction & Operation

1. Guided : (fig 1) It consists of a float connected to a pointer through a rope via a set of pulleys. The pointer with nylon roller glides smoothly over a calibrated gauge board, positioned parallel to the tank. The float accurately follows liquid level variations in vertical direction. The horizontal float movement is restricted between two guide wires firmly anchored to tank bottom. As such, the pointer is in 'TOP POSITION' when tank is 'EMPTY' and in 'BOTTOM POSITION' when 'FULL'. The pointer indicates level. The gauge board is supplied in 1 meter sections and multiple gauge boards are connected through gauge board brackets as per ordered measuring range.

Applications : Liquid with moderate turbulence.

2. Unguided : In this construction the float movement is not restricted through the guide wire as its movement is negligible.

Applications : Liquid with minimum turbulence.

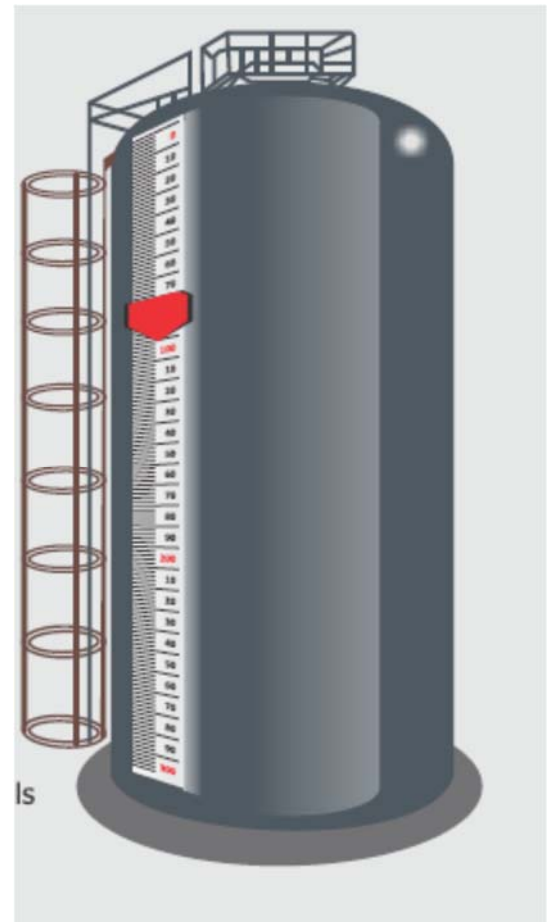

Typical Installation

Fig 1. Gauge board with Full Travel Mounted on Side of Ground Level Tank

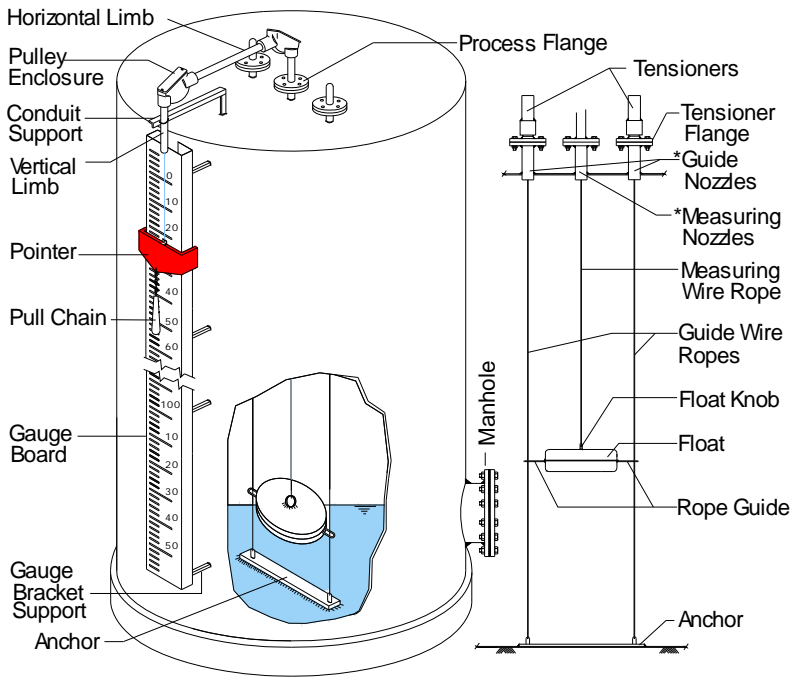

Fig 2. Gauge board with Full Travel Mounted on Side of Elevated Tank

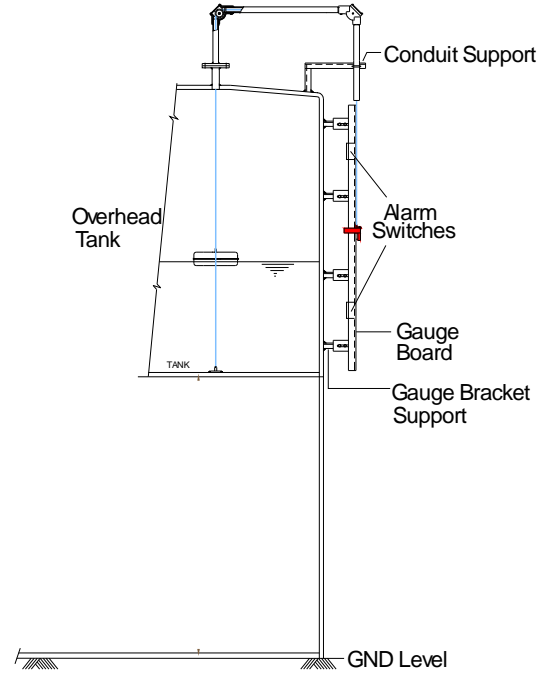

Fig 3. Gauge board with Full Travel Mounted below Elevated Tank

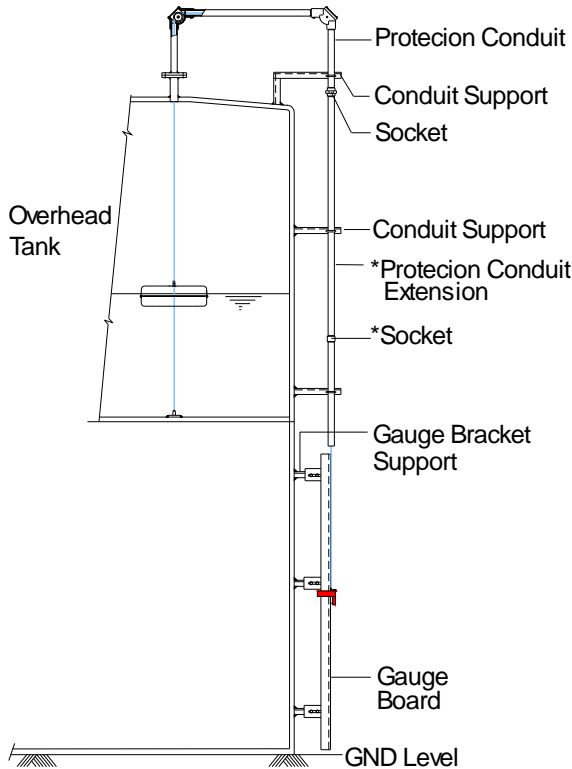
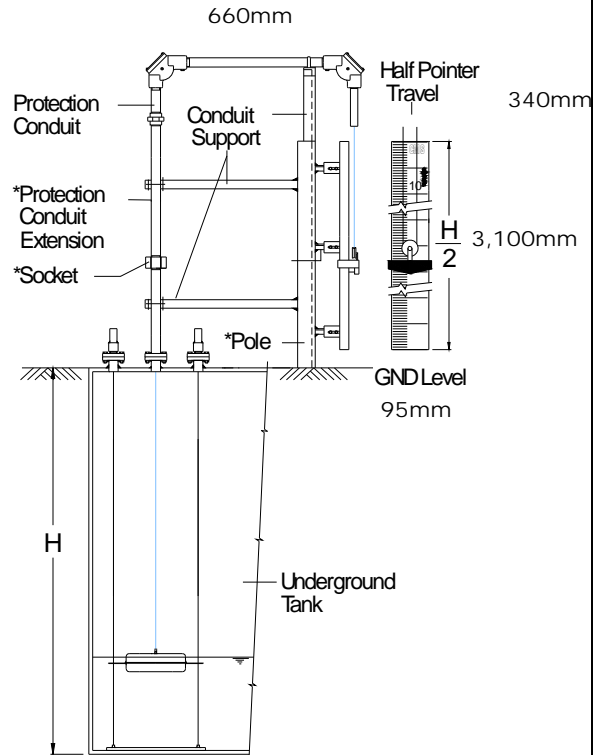
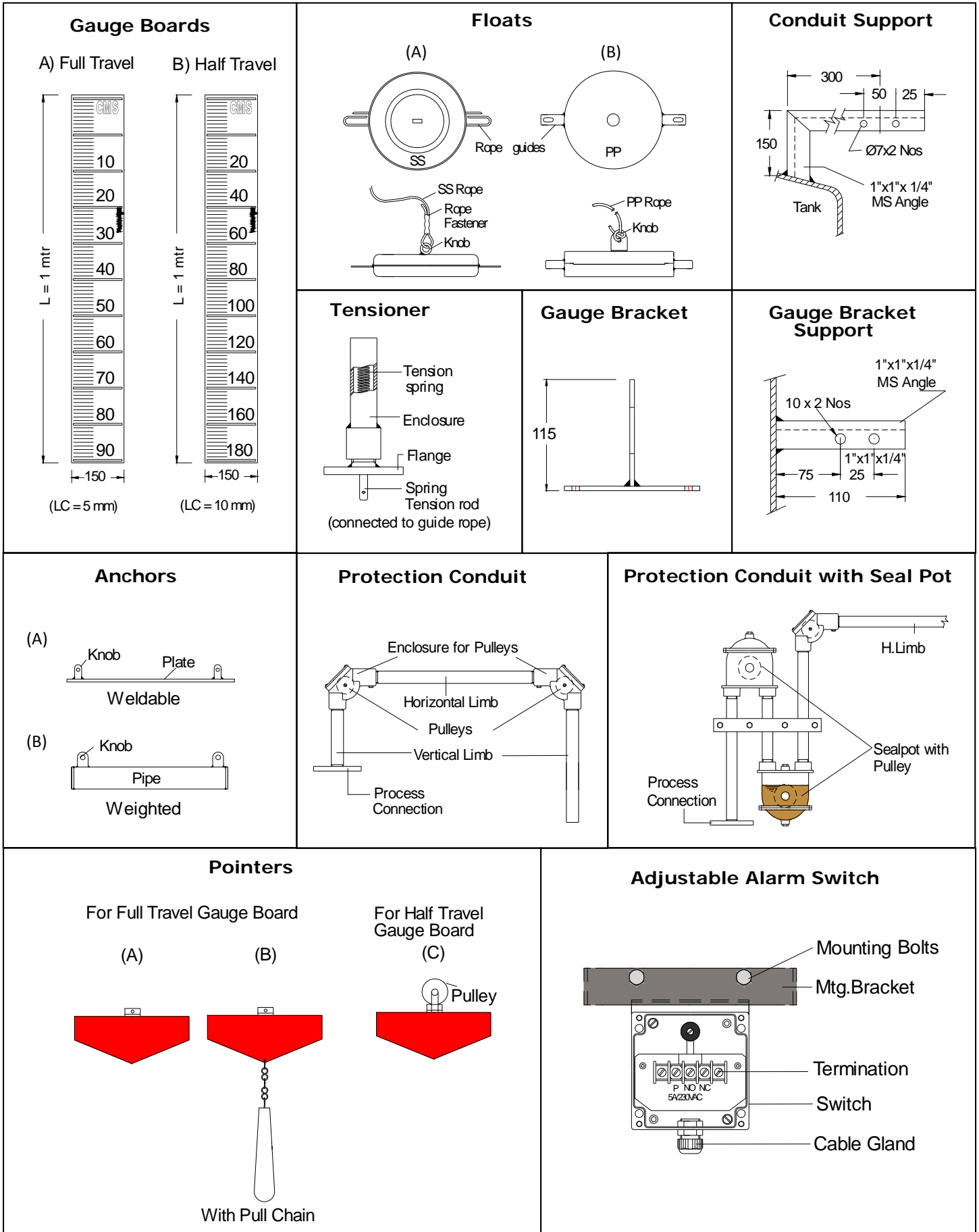

Fig 4. Gauge board with Half Travel Mounted on Underground Tank



*Customer scope

Components and Subassemblies Assembled at Site



Accessories

1. Counter Flange

(To be welded to tank nozzles)

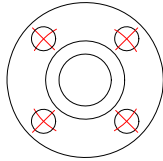

2. Measuring/ Guide Nozzles

(To be welded to tank)

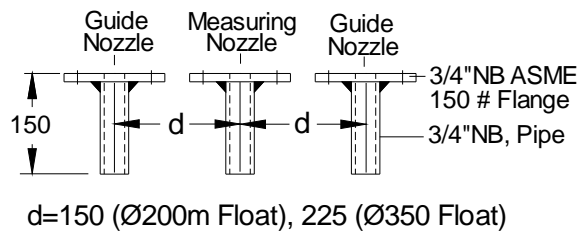

Gauge Board Mounting

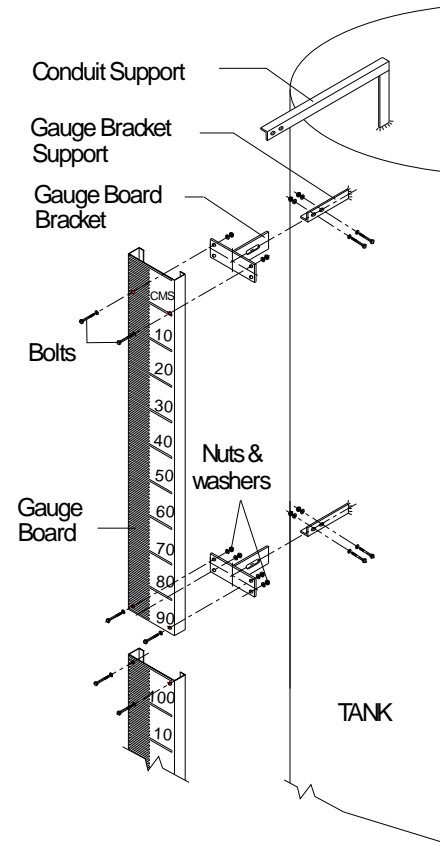

Specifications

Construction	Guided	Unguided
Range	1. 7.5 meters with Ø200 float 2. 15 meters with Ø350 float	3 meters with Ø200 float
Installation	Ground level tank or underground tank or elevated tank	
Liquid SG	≥ 0.8	
Max Temperature	80 °C (PP), 100 °C (ECTFE Ctd SS), 150 °C (SS)	
Max Pressure	Atmospheric	
Float	SS304/316/316L, PP, ECTFE (Hallar) coated SS304/316 x Ø200 or Ø350	
Float/Guide Wire Rope	SS304/316/316L, PTFE ctd SS304/316 x Ø 1.6 mm (multistrand) PP x Ø3 mm (multistrand)	
Process/Tensioner Connection MOC	CS, CS A105, PP, SS304 or SS316	
Process Connection	¾" or 1" or 1-1/2" NB ASME 150# flange	
Tensioner Connections	¾" or 1" or 1-1/2" ASME 150# flanges (2 nos.)	Not Applicable
Tensioner (2 nos.)	1. Cadmium pltd. steel spring in CS powder coated or PP enclosure 2. SS304 spring housed in SS304 enclosure 3. SS316 spring housed in SS316 enclosure	Not Applicable

Calibrated Gauge Board	<ol style="list-style-type: none"> 6" wide, white powder coated Aluminum or SS304 MOC with black graduations and numerical markings in black (minor) per 10 cm and in red (major) per 100 cm (34 mm height) for full travel. As above, but numerical markings in black (minor) per 20 cm and in red (major) per 200 cm for half travel. Volumetric scale in Litres or KL or BBL on request. 	
Resolution (Gauge Board)	5 mm (full travel), 10 mm (half travel)	
Pointer	Red powder coated CS or SS304 Pointer height = 60 mm for 7.5 meters range and 80 mm for 15 meters range	
Pointer Travel	<ol style="list-style-type: none"> Full for ground level, elevated tanks and underground tanks (< 4 meters) Half for underground tanks from 4 to 8 meters depth 	
Pull Chain	Nylon rope with PP handle for highly viscous liquids which tend to solidify at ambient temp	
Protection Conduit	$\frac{3}{4}$ " x GI or PP or SS304 pipe MOC <ol style="list-style-type: none"> Two vertical limbs of 285 & 195 mm One horizontal limb of 650 mm 	
Pulley & Pulley Enclosure (2 nos)	<ol style="list-style-type: none"> Cadmium plated steel with PTFE bush & SS shaft in powder coated cast Al enclosure (WP) PP pulley with PTFE bush & SS shaft in PP enclosure (WP) SS304/316 pulley with PTFE bush & SS shaft in WP Cast Al. powder coated enclosure (WP) SS304 pulley with PTFE bush & SS shaft in SS304 enclosure (WP) SS316 pulley with PTFE bush & SS shaft in SS316 enclosure (WP) 	
Anchor	<ol style="list-style-type: none"> Welded : SS304/316/316L plate , 25 W x 6 Thick (metallic tanks) Weighted : SS304/ 316/ 316L or ECTFE coated SS304 pipe (1" NB) or PP 50 mm OD <p>Note : Length of anchor = 300 (Ø200 float) and 450 mm (Ø350 float)</p>	Not Applicable
Rope Fasteners	SS316	
Gauge Board Brackets	Powder coated steel	
Conduit Support	MS	
Gauge Bracket Support	MS	
Seal Pot	<ol style="list-style-type: none"> 50 mmWC - Cast aluminum/ SS316/ PVC coated cast aluminum 200 mmWC - CS or SS316 	
Adjustable Alarm Switches	Micro switch, mono-stable, SDPT x ABS enclosure IP65, Switch rating- 5A, 250VAC One to four numbers (max)	
Accessories	<ol style="list-style-type: none"> Counter flanges (CS), nuts, bolts (CS) & CAF gaskets Measuring/ guide nozzles with flange (CS), nuts, bolts (CS) & CAF gaskets 	

Model Identification

FBG -																		
1. Construction x Pointer Travel																		
Guided x Full Travel	F																	
Guided x Half Travel	H																	
Unguided x Full Travel	U																	
2. Float MOC																		
SS304	N																	
SS316	S																	
SS316L	L																	
PP	P																	
ECTFE coated SS304	H																	
ECTFE coated SS316	V																	
Others	O																	
3. Float Size																		
Ø 200 mm	1																	
Ø 350 mm	2																	
4. Seal Pot																		
Without	W																	
50 mmWC x Aluminum	1																	
50 mmWC x SS316	2																	
50 mmWC x PVC coated Aluminum	3																	
200 mmWC x CS	4																	
200 mmWC x SS316	5																	
Others	O																	
5. No. of Alarm Switches																		
Without	W																	
One..... Four	1..4																	
6. Installation																		
Ground Level Tank	G																	
Under Ground Tank (Sump)	U																	
Elevated Tank	H																	
7. Calibrated Gauge Board x Pointer MOC																		
Aluminum Gauge Board x CS Pointer	1																	
Aluminum Gauge Board x CS Pointer with Pull Chain	2																	
SS304 Gauge Board x CS Pointer	3																	
SS304 Gauge Board x CS Pointer with Pull Chain	4																	
SS304 Gauge Board x SS304 Pointer	5																	
SS304 Gauge Board x SS304 Pointer with Pull Chain	6																	
8. Process/ Tensioner Connection MOC																		
CS	M																	
CS A105	A																	
SS304	N																	
SS316	S																	
PP	P																	
Others	O																	
9. Process Connection																		
¾" NB ASME 150# Flange	1																	
1" NB ASME 150# Flange	2																	
1-1/2" NB ASME 150# Flange	3																	
Others	O																	

10. Tensioner Connections (2 nos.)						
Without (Unguided)		W				
¾" NB ASME 150# Flange		1				
1" NB ASME 150# Flange		2				
1-1/2" NB ASME 150# Flange		3				
Others		O				
11. Tensioner (Spring + Enclosure)						
Without (Unguided Construction)		W				
Cadmium plated Steel Spring x CS powder coated Enclosure		1				
Cadmium plated Steel Spring x PP Enclosure		2				
SS304 Spring x SS304 Enclosure		3				
SS316 Spring x SS316 Enclosure		4				
Others		O				
12. Protection Conduit						
GI x ¾" NB Protection Conduit			1			
SS304 x ¾" NB Protection Conduit			2			
GI x ¾" NB Protection Conduit with Extension (Elevated or Underground Tanks)			3			
SS304 x ¾" NB Protection Conduit with Extension (Elevated or Underground Tanks)			4			
PP x ¾" NB Protection Conduit			5			
Others			O			
13. Pulley x Pulley Enclosure						
Cadmium plated steel Pulley x Cast Al powder coated Enclosure				1		
SS304 Pulley x Cast Al powder coated Enclosure				2		
SS304 Pulley x SS304 Enclosure				3		
SS316 Pulley x Cast Al powder coated Enclosure				4		
SS316 Pulley x SS316 Enclosure				5		
PP Pulley x PP Enclosure				6		
14. Anchor						
Without (Unguided)					W	
SS304 x Welded					A	
SS304 x Weighted					B	
SS316 x Welded					C	
SS316 x Weighted					D	
SS316L x Welded					E	
SS316L x Weighted					F	
PP x Weighted					G	
ECTFE coated SS304 x weighted					H	
15. Accessories						
Without						W
Counter Flanges (CS) + Nuts, Bolts (CS) + CAF Gaskets						F
Measuring/Guide Nozzles with Flange (CS) + Nuts, Bolts (CS) + CAF Gaskets						N
Others						O

Ordering Information

Model No x Range x Service Liquid and its Specific Gravity, Operating Temperature & Pressure

